

103-105 TESTE PER COLTELLI PROFILATI

103-105 CUTTER HEADS WITH PROFILED KNIVES

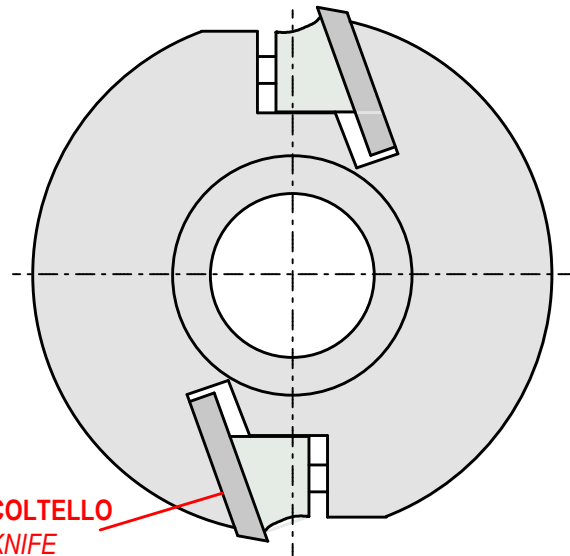

103 COLTELLI 40x4 E 50x4 KNIVES 40x4 E 50x4

MEC

Codice	D. mm.	B mm.	d. mm.	Z	
103 10	100	40	30	2	n max 8000
103 12	120	40	30-35	2	n max 7000

FORI A RICHIESTA-BORES ON REQUEST-mm 31.75-40-50

COLTELLI NON COMPRESI CON LA TESTA
KNIVES NOT INCLUDED WITH THE HEAD

105 COLTELLI 50x4 E 50x5.5 KNIVES 50x4 E 50x5.5

MEC

Codice	D. mm.	B mm.	d. mm.	Z	
105 10	100	50	30	2	n max 8000
105 12	120	50	30-35	2	n max 7000

FORI A RICHIESTA-BORES ON REQUEST-mm 31.75-40-50

COLTELLI NON COMPRESI CON LA TESTA
KNIVES NOT INCLUDED WITH THE HEAD

103

TESTE PORTACOLTELLI PER AVANZAMENTO MECCANICO.
SECONDO NORMATIVE EUROPEE EN 847-1.
CORPO IN ACCIAIO PER COLTELLI 40 x 4 mm. 50 x 4 mm

103

CUTTER HEAD FOR MECHANICAL FEED ACCORDING TO
THE EUROPEAN SAFETY RULE 847-1. STEEL BODY FOR
KNIVES 40 x 4 mm. 50 x 4 mm

105

TESTE PORTACOLTELLI PER AVANZAMENTO MECCANICO.
SECONDO LE NORMATIVE EUROPEE EN 847-1.
CORPO IN ACCIAIO PER COLTELLI 50 x 5.5. 50 x 4 mm

105

CUTTER HEAD FOR MECHANICAL FEED ACCORDING TO
THE EUROPEAN SAFETY RULE 847-1. STEEL BODY FOR
KNIVES 50 x 5.5 mm. 50 x 4 mm

RICAMBI-SPARE PARTS

Codice nr.	Dimensioni	
000/138B	38 mm	CUNEO-WEDGE-ART.103
138-48	48 mm	CUNEO-WEDGE-ART.105
000/008B	M10x20	GRANI-SCREWS-D.100
000/008C	M10x25	GRANI-SCREWS-D.120
000/034	5 mm	CHIAVE ESAG.-WRENCH