

452 FRESA PANTOGRAFO PER MEZZI TONDI

HALF ROUND CNC ROUTER CUTTER WITH CYLINDRICAL SHANK D.20 X 50.

FRESA PER RAGGIARE CON COLTELLI HW.
CON ATTACCO CILINDRICO D.20 X 50
E ROTAZIONE DX

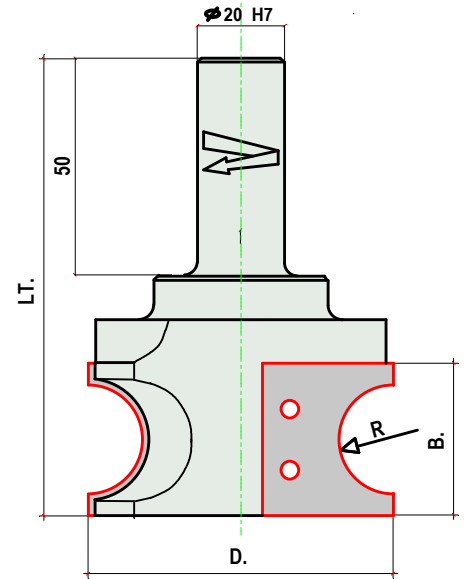

452

MEC

Codice nr. HW - RH	D. mm.	B. mm.	LT. mm.	R mm.	n max rpm	Coltellini di ricambio -Spare part knives		VITE	
						Codice nr.	Dimensioni	Codice nr.	Dimensioni
452.60	60	25	95	5 : 9	n max 14000	452 P5	25x25x2	401.08	M4x8
						452 P6	25x25x2	401.08	M4x8
						452 P8	25x25x2	401.08	M4x8
452.70	70	30	105	10 : 12.5	n max 12000	452 P10	35x30x2	401.08	M4x8
						452 P12.5	35x30x2	401.08	M4x8
452.90	90	50	120	15 : 20	n max 10000	452 P15	50x35x2	401.08	M4x8
						452 P20	50x35x2	401.08	M4x8
452.90A	90	60	135	22.5 : 25	n max 10000	452 P22.5	60x40x2	401.08	M4x8
						452 P25	60x40x2	401.08	M4x8

452 P5 R=5
452 P6 R=6
452 P8 R=8

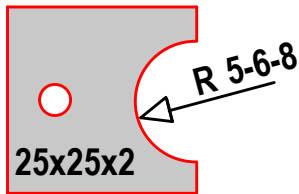

452 P10 R=10
452 P12.5 R=12.5

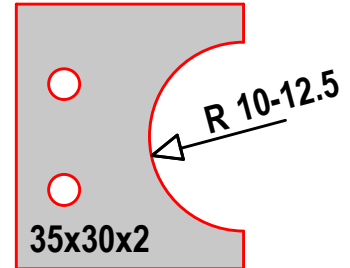

452 P15 R=15
452 P20 R=20

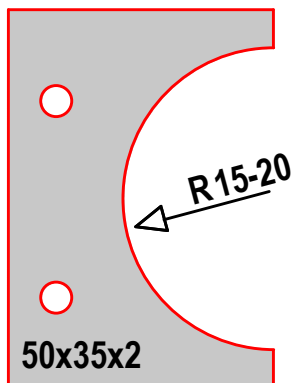

452 P22.5 R=22.5
452 P25 R=25

