

642 FRESE PER ANTINE

PROFILE CUTTER SET WITH CYLINDRICAL SHANK D.20 X 50.

642

MEC

GRUPPO FRESE SAGOMATE PER ANTINE, CON PROFILI INTERCAMBIABILI
ATTACCO CILINDRICO D.20X50 ROTAZIONE DX A RICHIESTA MANDRINO ISO O HSK

Codice nr. HW - RH	D.	B	P MAX	H MAX	n max
	mm.	mm.	mm.	mm.	rpm

642.A	110	47	10	24	n max 10000
642.B	120	47	15	24	n max 9000
642.C	130	47	20	24	n max 8500

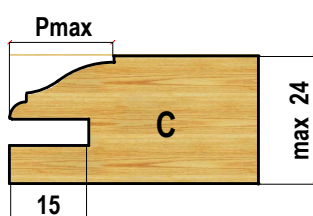
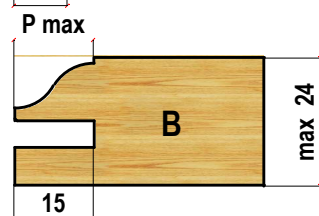
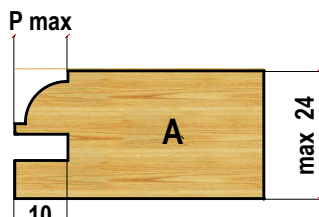
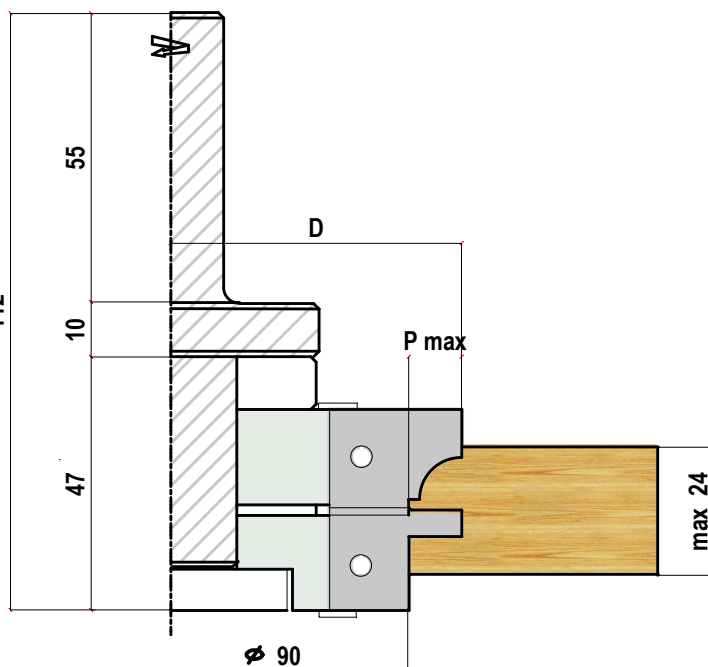

642 T FRESE CONTROSAGOMA PER ANTINE

COUNTER PROFILE CUTTER SET WITH CYLINDRICAL SHANK D.20 X 50.

642 T

MEC

GRUPPO FRESE CONTROSAGOMA PER ANTINE, CON PROFILI INTERCAMBIABILI
ATTACCO CILINDRICO D.20X50 ROTAZIONE DX A RICHIESTA MANDRINO ISO O HSK

Codice nr. HW - RH	D.	B	P MAX	H MAX	n max
	mm.	mm.	mm.	mm.	rpm

642.TA	110	47	10	24	n max 10000
642.TB	120	47	15	24	n max 9000
642.TC	130	47	20	24	n max 8500

